

Technical data sheet



Product features

Cooking range gas with oven 2/1

Model	SAP Code	00013709
SPT 90/80 21 G	A group of articles - web	Stoves



- Device type: Gas unit
- Power consumption of the zone 1 [kW]: 8
- Power consumption of the zone 2 [kW]: 8
- Power consumption of the zone 3 [kW]: 5
- Power consumption of the zone 4 [kW]: 3,5
- Type of internal part of the appliance 1 (eg oven): Gas
- Protection of controls: IPX4
- Material: AISI 304 top plate, AISI 430 cladding

SAP Code	00013709	Number of zones	4
Net Width [mm]	800	Power consumption of the zone 1 [kW]	8
Net Depth [mm]	900	Power consumption of the zone 2 [kW]	8
Net Height [mm]	900	Power consumption of the zone 3 [kW]	5
Net Weight [kg]	115.00	Power consumption of the zone 4 [kW]	3,5
Power gas [kW]	31.500	Type of internal part of the appliance 1 (eg oven)	Gas
Type of gas	Natural gas, propane butane		

Technical data sheet



Technical drawing

Cooking range gas with oven 2/1

Model	SAP Code	00013709
SPT 90/80 21 G	A group of articles - web	Stoves

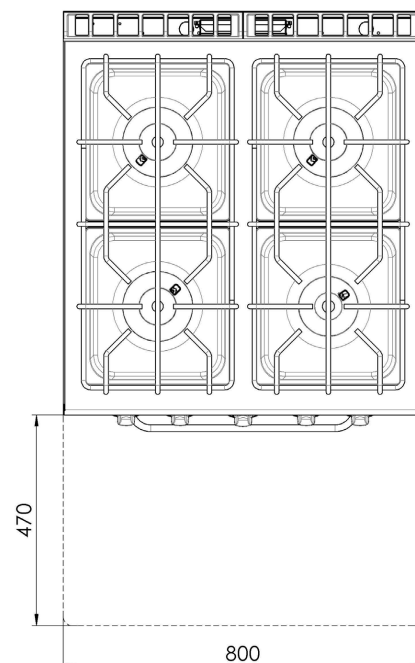
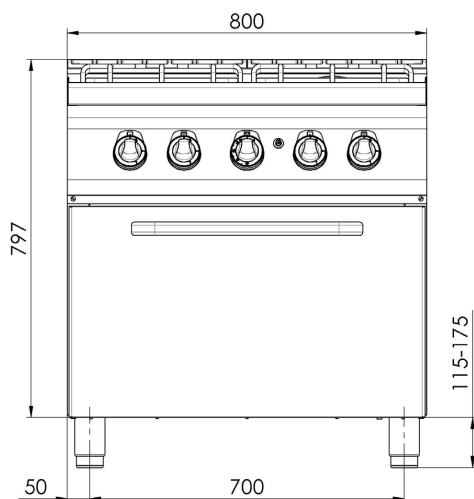
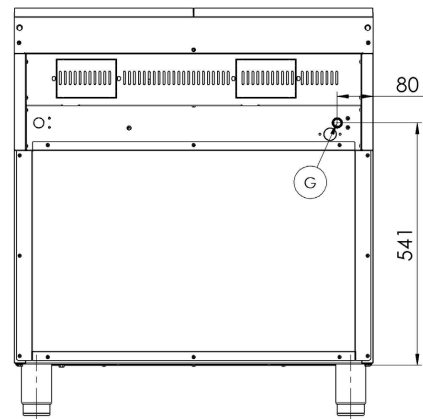
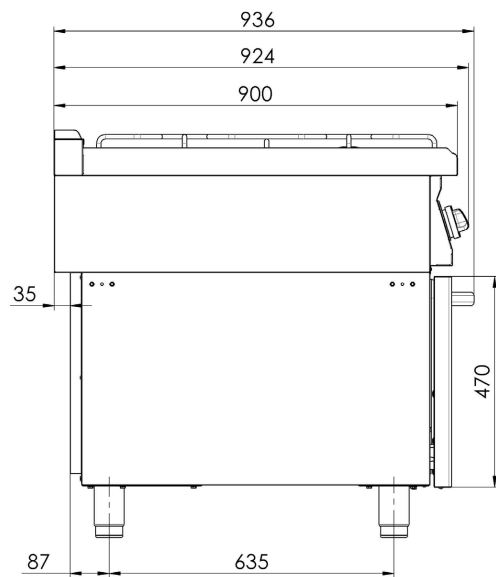

Technical data sheet



Technical parameters

Cooking range gas with oven 2/1

Model	SAP Code	00013709
SPT 90/80 21 G	A group of articles - web	Stoves

1. SAP Code:

00013709

2. Net Width [mm]:

800

3. Net Depth [mm]:

900

4. Net Height [mm]:

900

5. Net Weight [kg]:

115.00

6. Gross Width [mm]:

840

7. Gross depth [mm]:

970

8. Gross Height [mm]:

1160

9. Gross Weight [kg]:

130.00

10. Device type:

Gas unit

11. Construction type of device:

With substructure

12. Power gas [kW]:

31.500

13. Type of gas:

Natural gas, propane butane

14. Protection of controls:

IPX4

15. Material:

AISI 304 top plate, AISI 430 cladding

16. Worktop type:

With removable containers - convenient maintenance, cleaning and service access

17. Worktop material:

AISI 304

18. Worktop Thickness [mm]:

1.50

19. Number of zones:

4

20. Power consumption of the zone 1 [kW]:

8

21. Power consumption of the zone 2 [kW]:

8

22. Power consumption of the zone 3 [kW]:

5

23. Power consumption of the zone 4 [kW]:

3,5

24. Grid material:

Stainless steel

25. Service accessibility:

Trough the frontal panel

26. Adjustable feet:

Yes

Technical data sheet



Technical parameters

Cooking range gas with oven 2/1

Model	SAP Code	00013709
SPT 90/80 21 G	A group of articles - web	Stoves

27. Additional information:

Pozor: Toto zařízení není určeno pro přípravu všech typů pokrmů běžně připravovaných v troubě. Podrobné informace o použití zařízení a jeho omezeních naleznete v návodu k použití.

28. Number of burners/hot plates:

4

29. Type of gas cooking zones:

Classic

30. Burner type:

Brass, detachable

31. Oven Type:

gas static

32. Oven size:

GN 2/1

33. Oven material:

Stainless steel

34. Type of internal part of the appliance 1 (eg oven):

Gas

35. Gasket:

Yes

36. Connection to a ball valve:

1/2